



**PREMIUM AUDIO**  
**FOR AV CONFERENCING**  
**MICROFLEX® ADVANCE™**

©2020 Shure Incorporated.  
SHURE and the SHURE logotype are registered trademarks of Shure Incorporated or  
Shure Acquisition Holdings, Inc. For additional information, see [shure.com/trademarks](https://shure.com/trademarks).

## ADVANTAGES

AV conferencing has become an integral tool for business communication. But it's easy to forget that the majority of the content is actually carried by the audio, not the video. If the video fails during a videoconference, the meeting can go on virtually unimpeded. But if the audio fails, the meeting is over.

Since their introduction in 2016, Microflex® Advance™ Networked Array Microphones have come to be relied on to capture voice naturally, fit harmoniously with the room's appearance, and make it effortless to connect people for the world's leading enterprises. The platform includes advanced technology to provide outstanding sound quality, flexibility, and usability -- all without compromising the appearance of the room.

The industry-leading Microflex® Advance™ microphones have revolutionized versatile and elegant AV conferencing solutions that discreetly and precisely capture every word.



**SHURE**

# MEETING THE NEED

Audio is fundamental to successful collaboration. Poor intelligibility deprives us of valuable information and makes our brain work harder to compensate. We can experience fatigue, and we struggle to pay attention. Shure believes that good audio directly contributes to well-being, productivity, creativity, and connectedness of people in the workplace. We also believe that room designers and architects should not have to choose between sound and style.

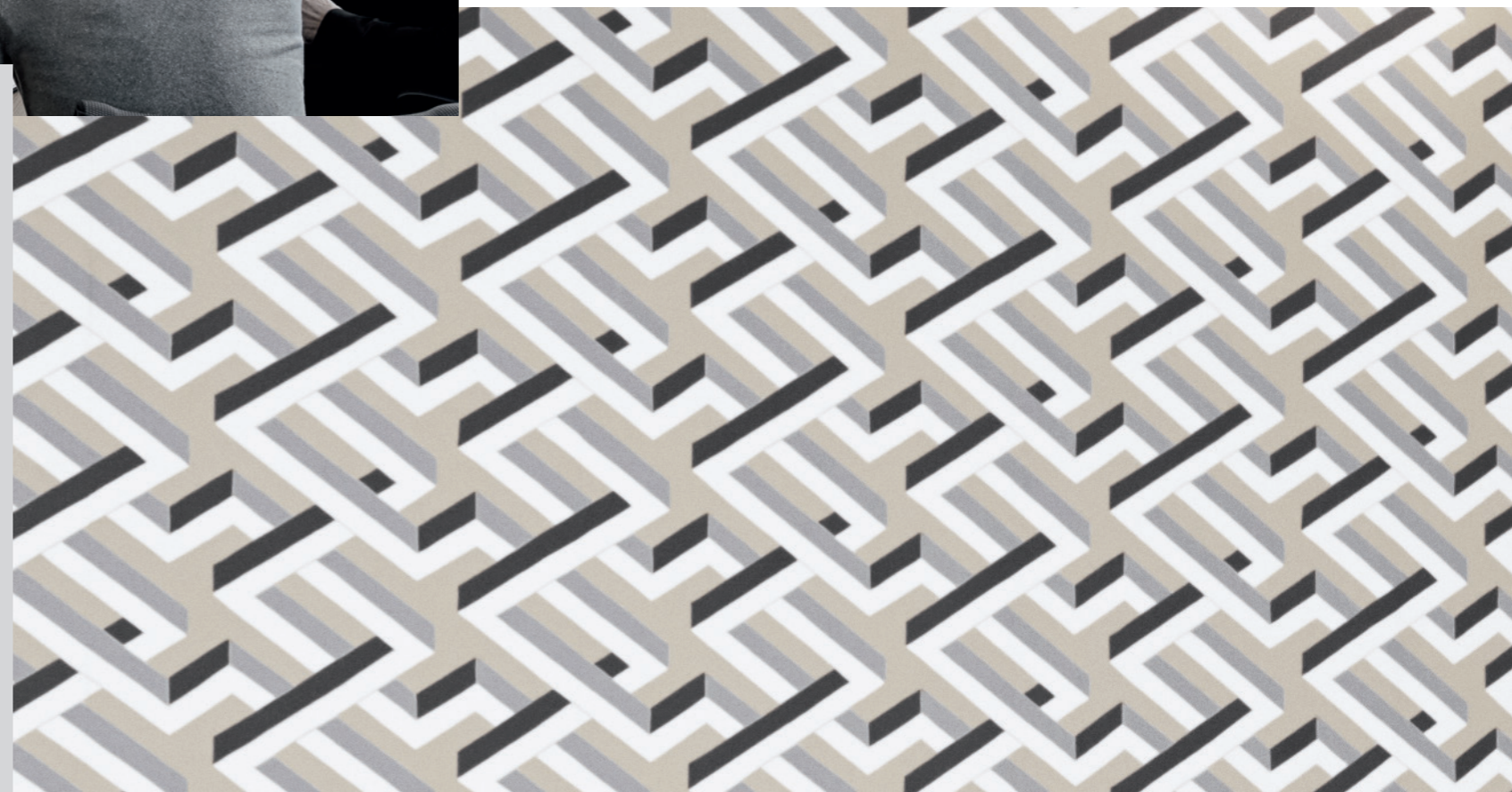

ADVANTAGES

ADVANTAGES

MXA910 CEILING ARRAY MICROPHONE WITH INTELLIMIX® +



+ MXA310 TABLE ARRAY MICROPHONE



+ MXA710 LINEAR ARRAY MICROPHONE WITH INTELLIMIX®

## SUPERIOR PERFORMANCE. UNMATCHED AESTHETICS.

Shure Microflex Advance array microphones feature revolutionary technologies that fundamentally change how audio is captured in AV conferencing environments. All are designed to work in harmony with available leading collaboration platforms, alongside Shure software tools that enable AV conference room designers to be more creative – and your meeting spaces to be more productive.

ADVANTAGES



ADVANTAGES



# WHAT'S IN IT FOR YOU?



## SYSTEM INTEGRATOR

The complete Shure networked systems ecosystem, from microphone to DSP to loudspeaker, are all deployed using Designer System Configuration software, enabling your teams to deliver great AV solutions more efficiently and faster than ever before.



## ARCHITECT / INTERIOR DESIGNER

Providing an audio solution that blends with any aesthetic, Microflex Advance enables architects and interior designers to create visually stunning workspaces, without sacrificing sound quality. It gives clients the style they want and the audio quality they need.



## C-LEVEL EXECUTIVES

Teams work more effectively and produce better results when communication between their members is natural and effortless. Microflex Advance makes poor audio a thing of the past, and allows teams to focus on their work.



## CFO / FINANCE DIRECTOR

Microflex Advance is a cost-effective audio solution that can be deployed in a variety of applications, eliminating the need for separate audio equipment purchases for audio-only and video conferencing use. Backed by industry-leading service and proven reliability, it presents a future-proof investment.



## USERS

Microflex Advance enables users to be more productive and creative – simply, to do their best work. It enhances communication by allowing everyone to hear, and be heard and understood clearly, while helping to remove unwanted noise and echo that contribute to listener fatigue during collaboration sessions.



## IT MANAGER / ADMIN

Microflex Advance integrates into your existing IT infrastructure, without affecting network speed or performance. Scalable to any size, with central control capabilities using SystemOn Audio Asset Management software, it makes AV/IT support more effective and less time consuming.

CEILING ARRAY MICROPHONE

# GREATER SIMPLICITY, FLEXIBILITY AND CLARITY.

The MXA910 Ceiling Array with IntelliMix®.



CEILING ARRAY MICROPHONE



## + MXA910 CEILING ARRAY WITH INTELLIMIX

### QUICKER COVERAGE

Industry-leading Steerable Coverage™ Technology allows you to configure up to eight highly directional lobes in three dimensions. Patent-pending Autofocus™ technology continually fine-tunes the position of each lobe in real time, for consistent sound if meeting participants adjust their location.

### INTELLIMIX DIGITAL SIGNAL PROCESSING

The MXA910 with IntelliMix includes powerful Shure DSP algorithms – patented acoustic echo cancellation, noise reduction and automatic mixing – providing all of the signal processing needed for echo- and noise-free audio in A/V conferencing applications.

### UNPRECEDENTED WORKFLOW EFFICIENCY

The MXA910 provides full room coverage right out of the box. And with free Designer System Configuration Software, rooms can be easily configured anywhere offline in minutes, and fine-tuned live while onsite. Even audio routing between Shure devices can be completed ahead of time – deploying room solutions has never been faster.

### SCALABLE FOR MANY SPACES

Multiple MXA910s and a single IntelliMix P300 Digital Signal Processor can be combined in a system that offers a distributed DSP approach that is simple, powerful and cost effective, allowing unprecedented room expansion and scalability – including applications with camera tracking and voicelift requirements.

### ELEGANT DESIGN

Seamlessly integrate arrays within a meeting space, no matter what the design aesthetic. Numerous mounting options, including pole or suspension mounts. The MXA910 is available in three colors (white, aluminum black), or custom painted as desired.



LINEAR ARRAY MICROPHONE

LINEAR ARRAY MICROPHONE



+ MXA710 LINEAR ARRAY WITH INTELLIMIX

## COLLABORATION WITHOUT BOUNDARIES.

### STREAMLINED DEPLOYMENT

The MXA710 represents the next innovation in array technology, and is an integral part of the Shure networked systems ecosystem. The entire audio signal chain utilizes Designer System Configuration software to get rooms up and running faster than ever.

### PLAYS WELL WITH OTHERS

Today's collaboration technologies are more powerful than ever. Every Microflex Advance array microphone is fully certified and compatible with the leading platform, making the MXA710 an ideal choice for audio capture in any room.

### MEET EVERY NEED

Available in two lengths and three colors, the MXA710 provides unprecedented installation flexibility - whether on a wall next or under a display, overhead from the ceiling, or flush mounted in a table.

### QUICKER COVERAGE

Industry-leading Steerable Coverage™ Technology allows you to configure up to 4 (two foot array) or 8 (four foot array) lobes for optimal audio capture. Patent-pending Autofocus™ technology continually fine-tunes the position of each lobe in real time, for consistent sound if meeting participants shift in their seats.

### INTELLIMIX DIGITAL SIGNAL PROCESSING

Every MXA710 ships with Shure IntelliMix DSP onboard – patented acoustic echo cancellation, noise reduction and automatic mixing – providing all of the signal processing needed for echo- and noise-free audio in A/V conferencing applications.



**MXA310 TABLE ARRAY MICROPHONE** +

## GREAT AUDIO. ON THE TABLE.

### STEERABLE COVERAGE

With free Designer System Configuration software, you can specify the polar pattern for each lobe. Patterns include cardioid, supercardioid, hypercardioid, omnidirectional, bi-directional and an exclusive toroid pattern that rejects audio from above.

### SOUND TOOLS

An integrated automix out with adjustable parametric EQ helps improve clarity and reduces noise – for improved audio quality, intelligibility and seamless interaction between conference sites.

### FLEXIBLE NETWORKING

Mix, route and manage the signals from up to four coverage areas as discrete channels on a AES67 or Dante audio network over a single Ethernet cable. Dante Domain Manager ready for enterprise-wide deployments. Use the automix channel to easily route audio to additional devices like the ANIUSB-MATRIX audio network interface for simple integration with leading software codec solutions.

### MUTE CONTROLS

Program the touch-sensitive mute button for toggle, push-to-mute, push-to-talk or disable settings to send controls to external devices.

### INTUITIVE LED DISPLAYS

The configurable LED light ring includes 17 colors and shows the mute status of the microphone in use and displays lighted segments during set-up to confirm coverage areas and selected automix settings.



SOFTWARE

SOFTWARE

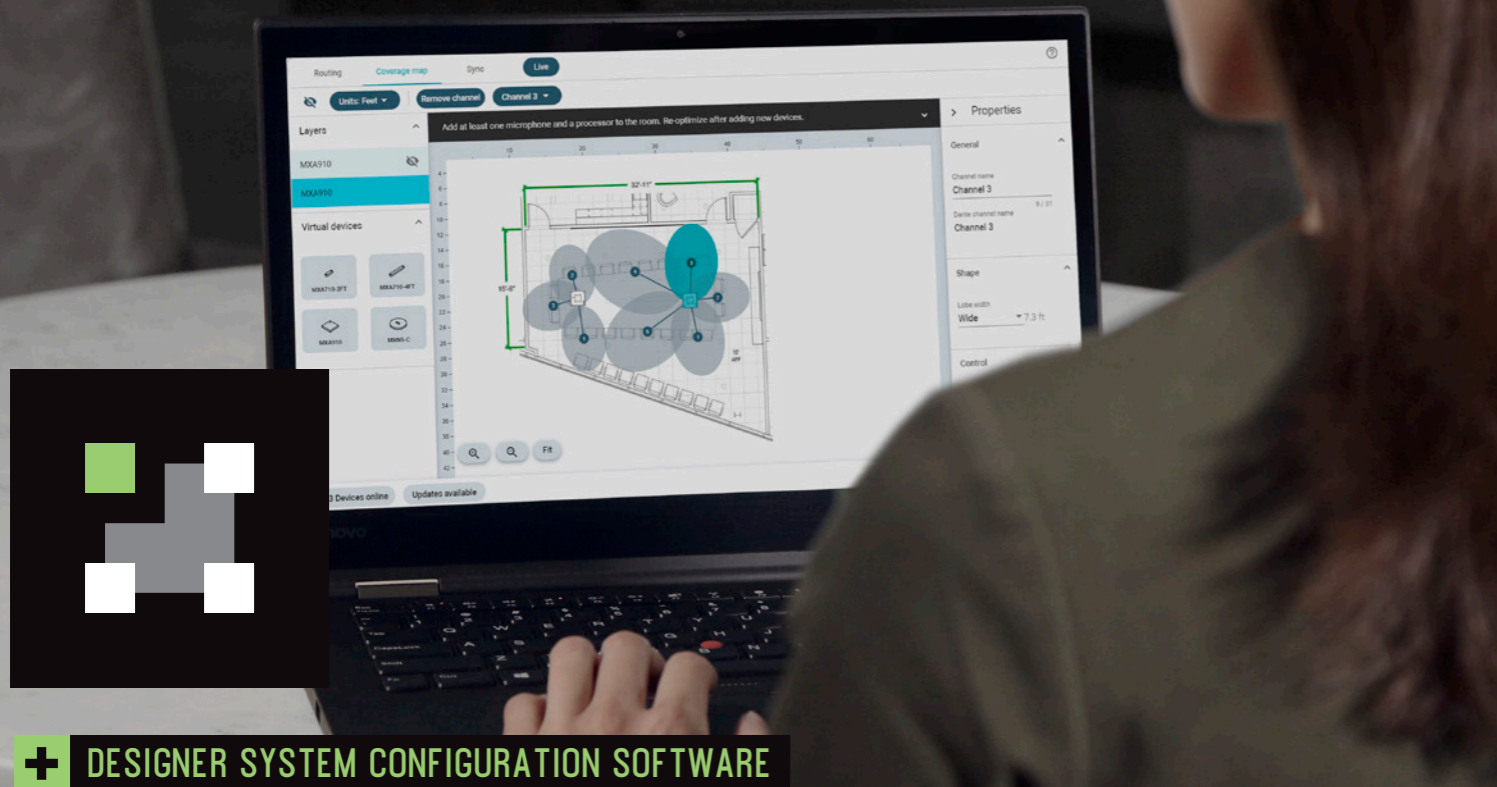

+ DESIGNER SYSTEM CONFIGURATION SOFTWARE

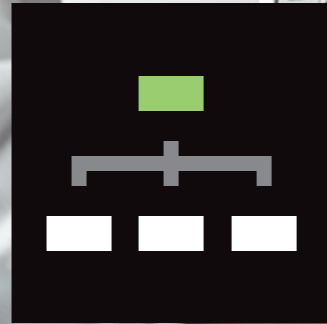

+ SYSTEMON® AUDIO ASSET MANAGEMENT SOFTWARE



## PLAN AMAZING AUDIO.

Simply set-up your Shure Audio Ecosystem with this free software. Deploy more rooms in less time enabling you with more efficiency and consistency. Design projects online and offline.



### PRE-CONFIGURED SETTINGS

Configure the Shure Audio Ecosystem for conferencing



### STEP AND REPEAT

Create templates based on common floor plans.



### PASS IT ON

Room configurations can be saved and shared with colleagues.



### SINGLE HUB

Firmware updating and Dante™ audio routing.

## CONQUER COMPLEXITY AND SCALE.

You can't be everywhere at once but everywhere can be with you. Update and monitor your Shure Audio Ecosystem remotely. From managing inventory and battery health in real-time and troubleshoot on the go.



### PEACE OF MIND

Stay one step ahead with text and email alerts for potential issues before they happen.



### TIME SAVING

Maximize control of your organization's audio and update firmware on the go.



### SECURE SYSTEM

Customize access and permissions for a tailored user experience



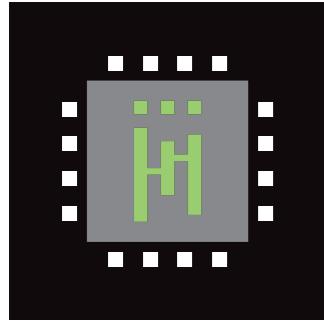

## + INTELLIMIX ROOM®

# AV THAT SPEAKS IT.

IntelliMix® Room, the first audio processing software fully optimized for Shure conferencing microphones. Simply download and deploy to in-room Windows 10 devices, and bring conferencing into the future. No custom setups or special hardware needed to enjoy crystal-clear audio on all video conference calls.

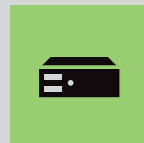

### THE HARDWARE'S ALREADY THERE.

IntelliMix® Room effectively turns the in-room PC into a Shure device. All configuration is managed in our Designer software and replicable through easy-to-use templates.

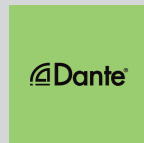

### DANTE ONBOARD.

Once the PC has IntelliMix Room onboard, it has Dante audio networking too. No other software license is needed to route audio to or from that PC.



### ALWAYS STANDING BY.

Running in the background of Windows, the software restarts automatically, even if the PC loses power or has to reboot after updates.



### NO COMPLICATED AUDIO ROUTING.

IntelliMix Room installs with its own audio driver. Once selected from the Audio Device dropdown in the Soft Codec of choice, the client is ready to talk.



### ENTERPRISE-WIDE LICENSING.

A centrally managed license lets clients easily and effectively deploy the software through their global corporate network.



### PUT A STOP TO EAVESDROP.

All connected Shure devices feature Shure Audio Encryption, so the only ones to hear it are the ones on the call.



## MAKE SIMPLE THE NEW STANDARD.

Now all it takes to optimize audio is award-winning Shure MXA mics and a PC running a conferencing application and IntelliMix® Room.

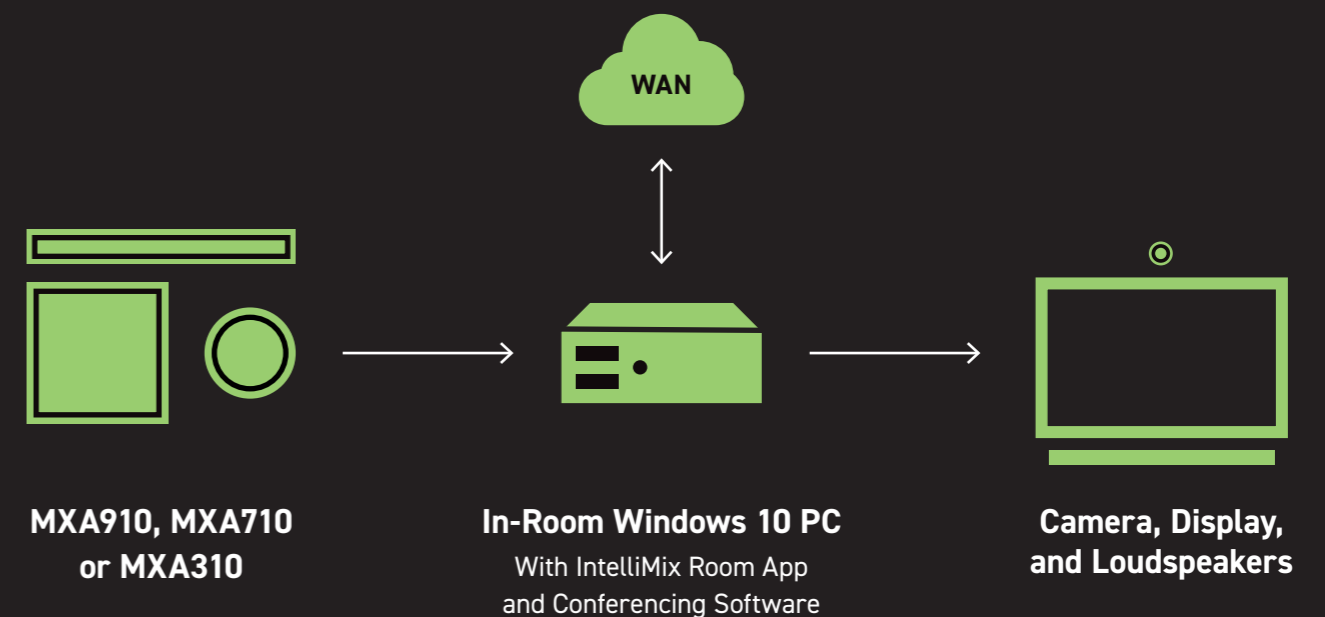

# APPLICATION FLEXIBILITY

Match single or multiple arrays to the AV conferencing needs of rooms of any size, configuration or activity: formal presentations, intimate discussions, distance learning or collaborative work.

## + TABLE ARRAY COVERAGE MAPS

**+ Small Rectangular Table**  
1 Table Array  
Profile  
6 Chairs  
1 Rectangular Table  
**1 Bi-Directional Pattern**  
**2 Cardioid Patterns**

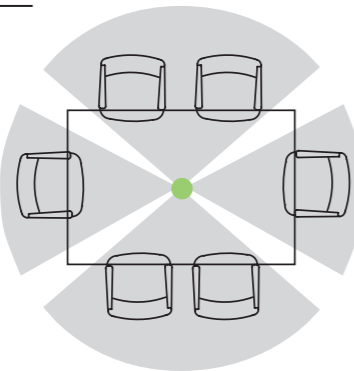

**+ Medium Round Table**  
1 Table Array  
Profile  
9 Chairs  
1 Round Table  
**1 Toroid Pattern**

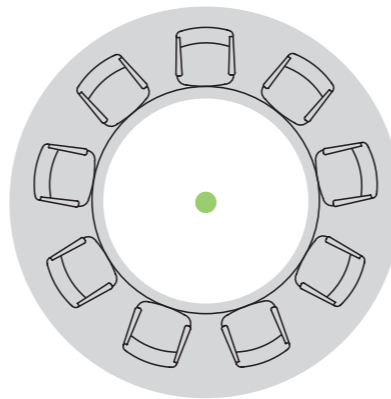

**+ Square Table**  
1 Table Array  
Profile  
8 Chairs  
1 Square Table  
**4 Supercardioid Patterns**

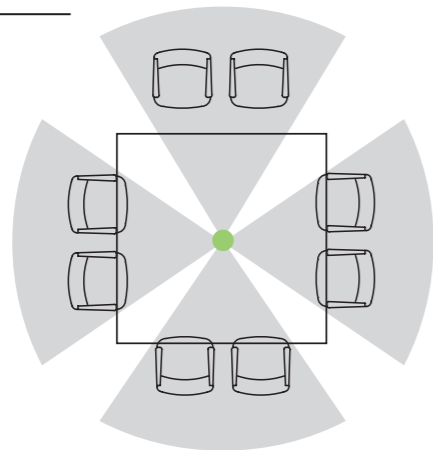

**+ Rectangular Table**  
1 Table Array  
Profile  
5 Chairs  
1 Rectangular Table  
**1 Supercardioid Pattern**  
**2 Cardioid Patterns**

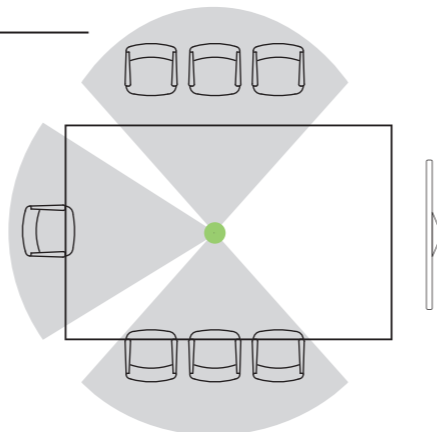

## + LINEAR ARRAY COVERAGE MAPS

**+ Small Rectangular Table**  
MXA710-2FT  
Coverage Distance: Up to 16 ft  
Channels used: 3 of 4  
Mic Coverage: Default  
Horizontal Wall Installation  
Profile  
9 Chairs  
1 Rectangular Table

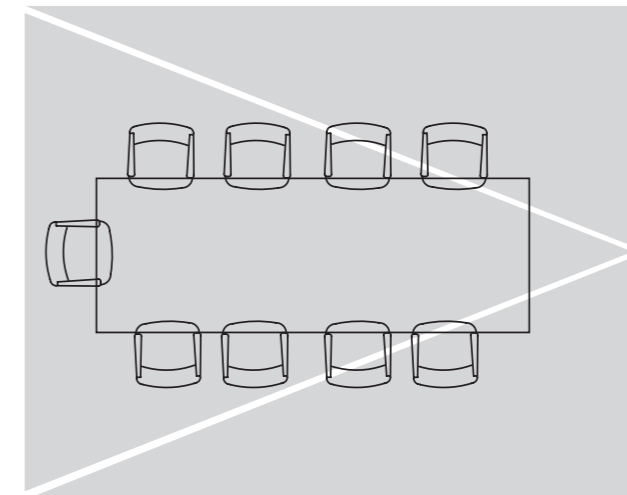

**+ Large Rectangular Table**  
MXA710-4FT  
Coverage Distance: Up to 20 ft  
Channels used: 5 of 8  
Mic Coverage: Custom/Optimized  
Horizontal Wall Installation  
Profile  
13 Chairs  
1 Rectangular Table

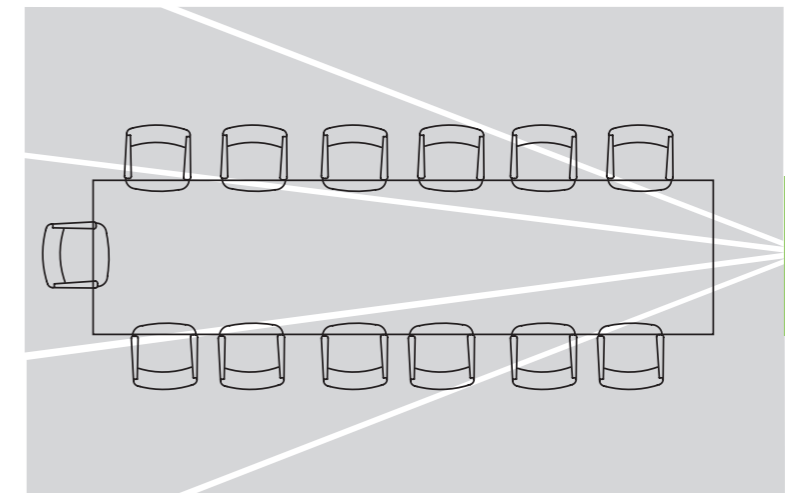

## + CEILING ARRAY COVERAGE MAPS \*

### + Large Conference Room 2 Ceiling Arrays

Profile  
28 Chairs  
1 Rectangular Table

14 Coverage Areas

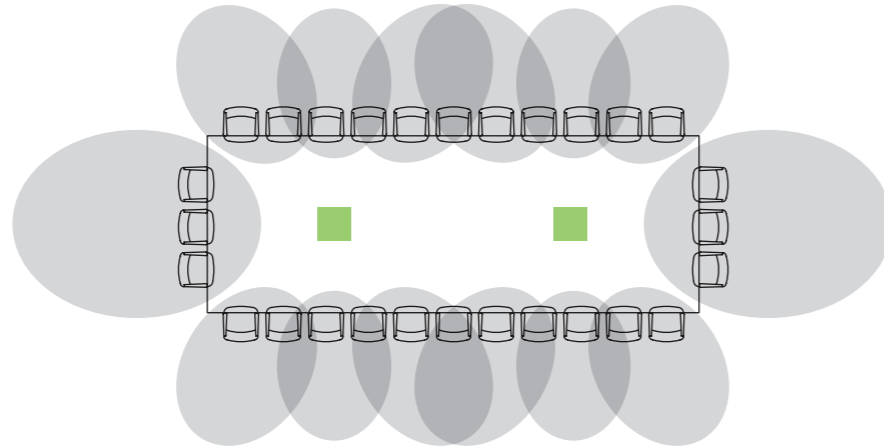

### + Medium Conference Room 1 Ceiling Array

Profile  
14 Chairs  
1 Rectangular Table

8 Coverage Areas

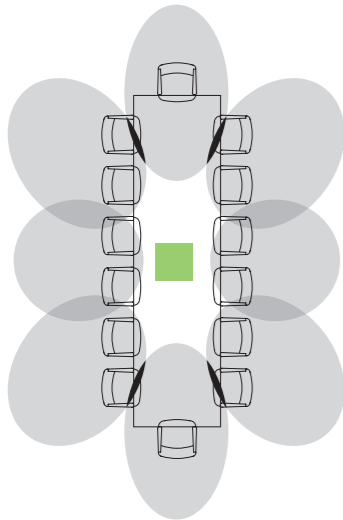

### + Videoconference Room 1 Ceiling Array

Profile  
21 Chairs  
3 Rectangular Tables

8 Coverage Areas

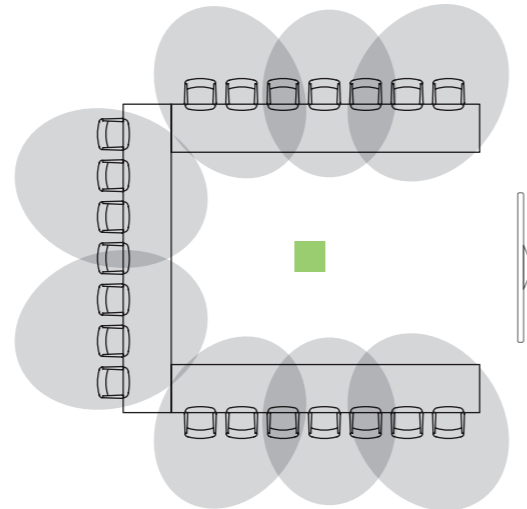

### + Classroom / Presentation Room 1 Ceiling Array

Profile  
16 Chairs  
4 Rectangular Tables

7 Coverage Areas

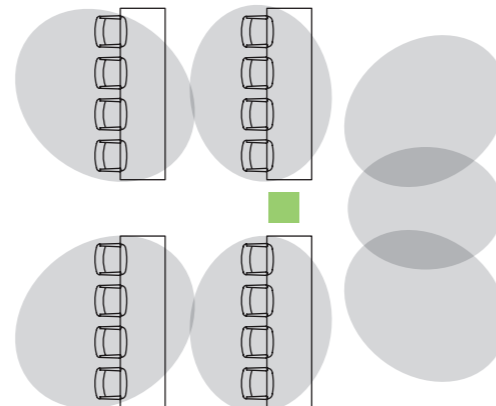

\* Coverage Capabilities  
Installed at a height of 3 meters (ten feet),  
Ceiling Arrays capture audio from seated  
participants to a recommended area of  
9 meters (30 feet) in diameter, meeting the STIPA "A"  
intelligibility rating.

\*\* Note:  
Ceiling Arrays are capable of picking up participants  
beyond 9 meters (30 feet).

\*\* Room conditions:  
RT60 (reverb time)  
= 500 ms @ 1kHz, weighted room noise  
= 40dB SPL(A), IEC-602682-16.

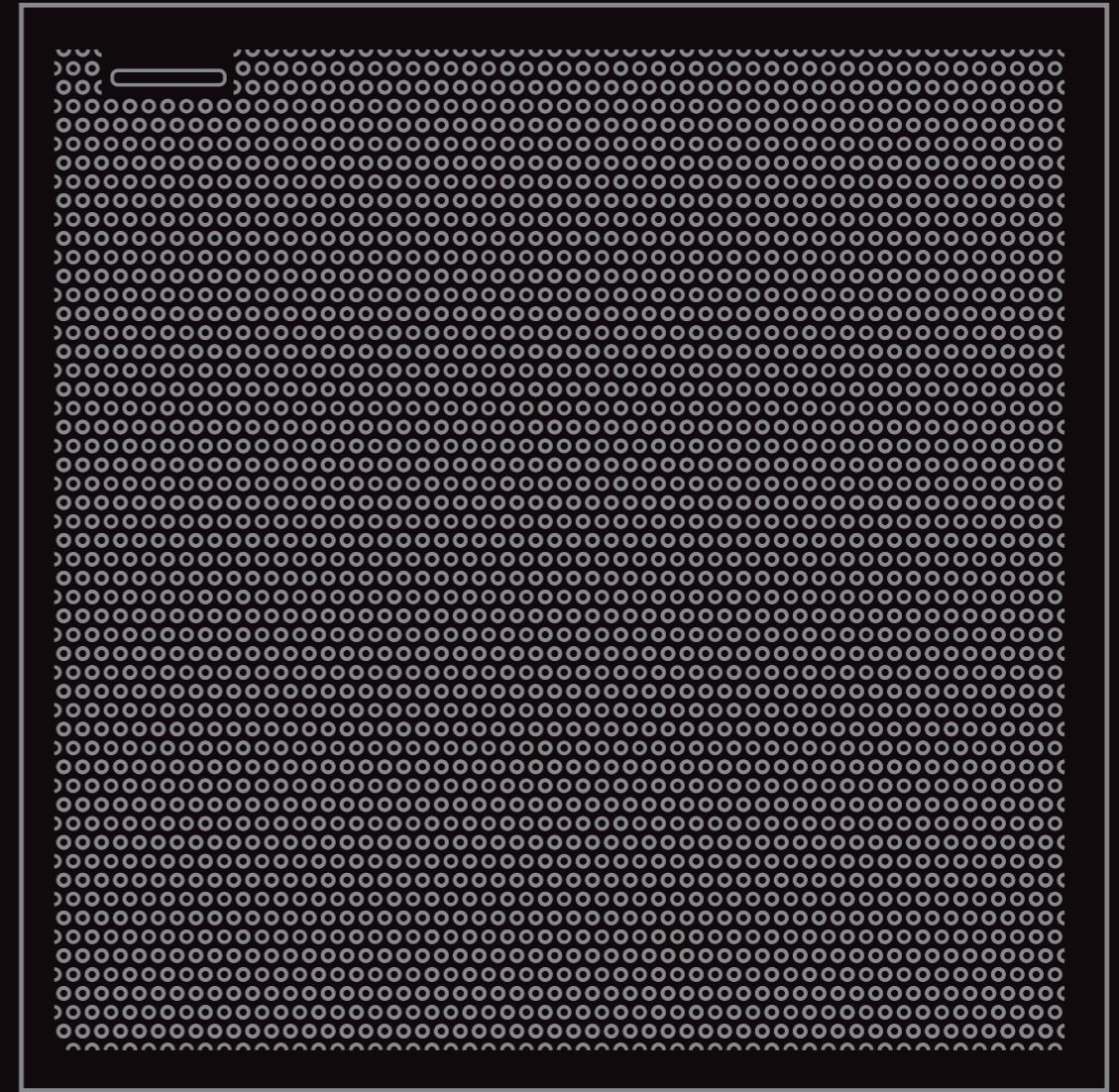

# BETTER TOGETHER.

Shure Networked Audio Processors and Interfaces quickly and easily integrate with Microflex Advance providing high-quality audio conferencing solution with extremely intelligible meeting sound.



## + INTELLIMIX® P300 AUDIO CONFERENCING PROCESSOR

The IntelliMix P300 Audio Conferencing Processor offers DSP algorithms optimized for AV conferencing applications with Microflex Advance microphones. Featuring acoustic echo cancellation, noise reduction and automatic gain control for up to 8 Dante channels, the P300-IMX helps to ensure echo- and noise-free conference room audio that facilitates communication and collaboration. Easy to install and configure using Designer System Configuration software, the P300 provides Dante, analog, USB and mobile connectivity options that make joining room systems and collaborating with laptops and mobile devices easier than ever.

- Features**
- IntelliMix® DSP
  - 10 Dante input channels, 8 output channels
  - 2 analog audio inputs / 2 outputs
  - USB 2.0
  - 15 x 12 Matrix Mixer
  - 3.5mm Mobile input (1/8")
  - Easy deployment with Designer System Configuration software
  - Single Ethernet connectivity
  - 10 configuration presets
  - Third-party control system compatible
  - Dante Domain Manager ready
  - Power over Ethernet plus (PoE+)
  - 8 Channels of Acoustic Echo Cancellation

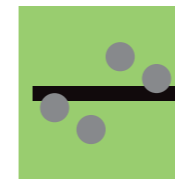

### AUDIO PERFORMANCE

Enhanced meeting room audio for natural communication and better interaction in AV conferences with remote team members.



### INTUITIVE CONNECTIONS

Industry-first mute sync functionality when MXA microphones are connected to the P300 for better operation with leading third-party software codecs.



### SIMPLICITY

Pre-defined templates for system configuration reduce programming time, and allow installation within seconds.



### SHURE AUDIO ENCRYPTION

When using Microflex Advance together with the IntelliMix P300 Audio Conferencing Processor and selected Shure Audio Network Interfaces, Shure Audio Encryption with AES-256 encryption technology can help protect confidential content.



**+ ANIUSB-MATRIX USB AUDIO NETWORK INTERFACE WITH MATRIX MIXING**

The ANIUSB-MATRIX Audio Network Interface provides a versatile hub for collaboration in small to medium-size meeting rooms, suitable for both room video conference systems and soft codec solutions. The device presents a budget-friendly companion to Microflex Advance microphones, for AV conferencing applications that leverage the integrated processing functionality of existing video codecs in the room.

**Features**

- 4 Dante audio inputs / 2 outputs
- 1 analog audio input / 1 output
- USB 2.0
- 6 X 4 Matrix Mixer
- Per channel Equalizer, Mute, Limiter, Gain
- Easy deployment with Designer System Configuration software
- Single Ethernet connectivity
- 10 configuration presets
- Dante Domain Manager ready
- Third-party control system compatible
- Power over Ethernet (PoE)

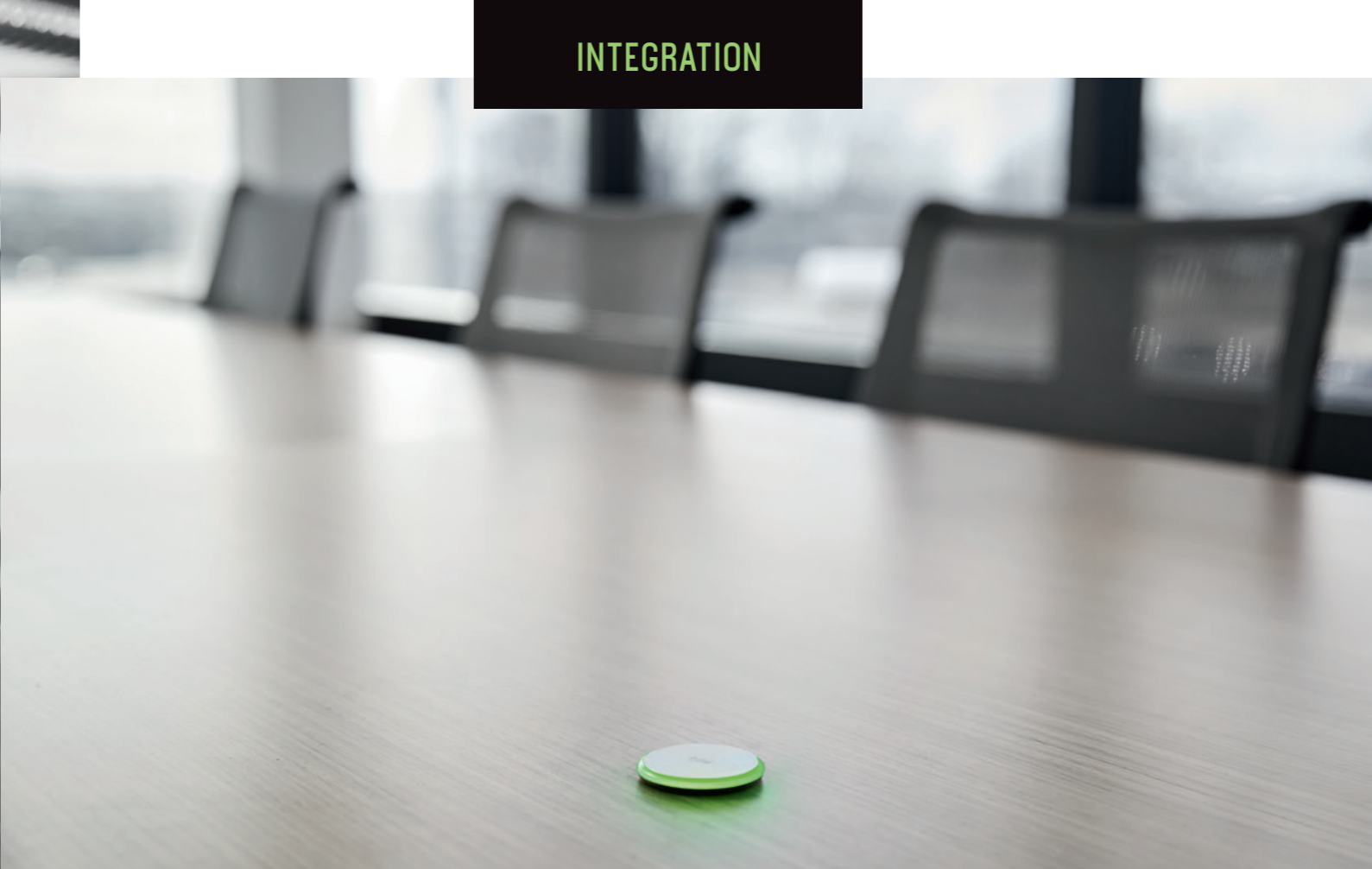

**+ MXA NETWORK MUTE BUTTON**

The MXA Network Mute Button is a configurable PoE-powered mute button accessory designed for Shure networked audio products, including Microflex® Advance™ Array Microphones as well as the IntelliMix® P300 and IntelliMix Room DSPs, and ANIUSB-MATRIX. One or many of the low-profile touch sensitive mute buttons can be configured to mute one or multiple microphones, depending on user needs or room configurations.

**Features**

- Designer System Configuration software for easy setup and configuration
- SystemOn™ Asset Management for remote management & troubleshooting
- PoE powered
- Compatible with third party control systems via programmable control strings
- LED status ring with configurable colors and brightness
- Configurable as toggle, push to talk and push to mute functionality
- IP1X rated
- Easy table installation in 1" (25mm) or 7/8" (22mm) holes



## INSTALLATION



**SHURE**

# INSTALLATION SOLUTIONS

MXA910 Ceiling Array Microphones are designed for suspension, pole and flush mounting in metric or imperial formats. The sleek, linear form factor of the MXA710 allows for placement virtually anywhere in a meeting space, including on a wall, around a display, ceiling, or into a conference room table. MXA310 Table Array Microphones feature through-the-table mounting kits. The A310-FM mounting accessory also allows flush mounting in a table.



**Integrated Vibration Isolation**  
Prevents transmission of mechanical noise through the microphone.

**Plenum-Rated**  
UL 2043 suitable for air handling spaces and plenum compliant when used with supplied Fyre Wrap® accessory.

**Dust Protection**  
IEC 60529 IP5X Dust Protected

## INSTALLATION

### MXA910 CEILING ARRAY MOUNTING OPTIONS



+ CEILING GRID



+ SUSPENSION MOUNT



+ VESA POLE MOUNT



+ HARD CEILING

Requires A910-HCM accessory

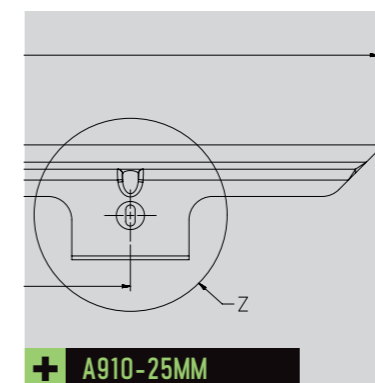

+ A910-25MM

Configures a 600 mm Ceiling Array for a 625 mm grid.

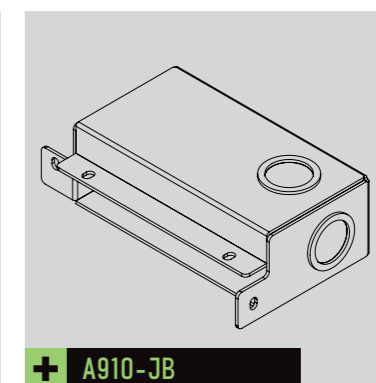

+ A910-JB

Allows the Ethernet cable connected to the array to be installed inside flex conduit.

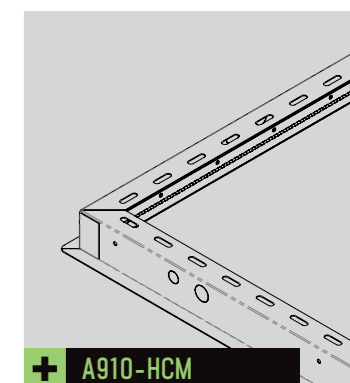

+ A910-HCM

Hard Ceiling Mount  
Can be pre-installed in the ceiling and the MXA910 installed later using the access door. Provides knockouts for conduit connections.

## MXA310 TABLE ARRAY MOUNTING OPTIONS

### + TABLE ARRAY MOUNTING KIT (INCLUDED)

Cable management solutions for on-the-table or through-the-table applications; includes mounting tube/wingnut.  
MXA310 retrofits existing Shure table mounted MX395, MX396, MX392 boundary microphones.

### + A310-FM FLUSH MOUNT (OPTIONAL)

Allows MXA310 Table Array to be mounted flush in the table; includes rubber isolation to prevent mechanical vibrations.  
Available in black and aluminum finishes; paintable to match table surface.



## MXA710 LINEAR ARRAY MOUNTING OPTIONS



+ SUSPENSION MOUNT



+ BELOW DISPLAY WITH THIRD-PARTY MOUNT

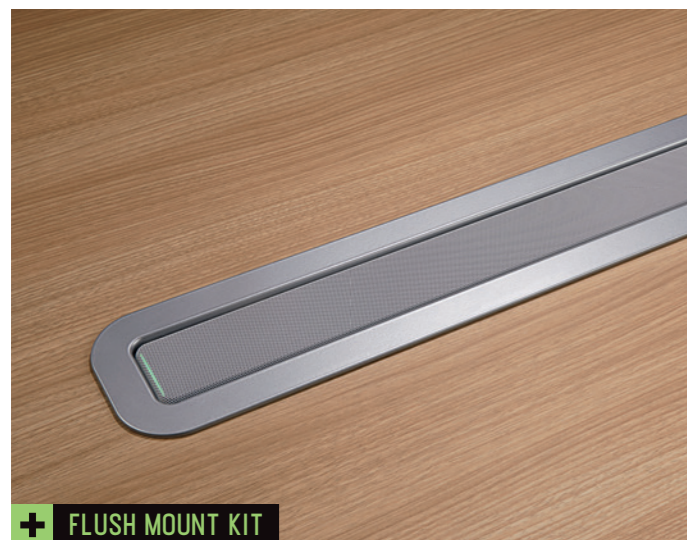

+ FLUSH MOUNT KIT



+ WITH A710-DS DESKTOP STAND

## EXPRESSIVE FINISHES

Ceiling and Table Array microphones are available in black, white and aluminum finishes to match room aesthetics or the finishes of other AV system components. The Ceiling Array microphone can also be custom-painted to fit your environment.

